

**Design technology**  
**Higher level and standard level**  
**Paper 2**

Thursday 12 May 2016 (morning)

Candidate session number

--	--	--	--	--	--	--	--	--	--

1 hour 30 minutes

**Instructions to candidates**

- Write your session number in the boxes above.
- Do not open this examination paper until instructed to do so.
- Section A: answer all questions.
- Section B: answer one question.
- Write your answers in the boxes provided.
- A calculator is required for this paper.
- The maximum mark for this examination paper is **[50 marks]**.



### Section A

Answer **all** questions. Write your answers in the boxes provided.

1. **Figure 1** shows a sketch of a typical Tetra Pak carton. Tetra Pak cartons were developed in Sweden in 1951 to replace the glass containers commonly used at the time.

**Figure 1: A sketch of a typical Tetra Pak carton**

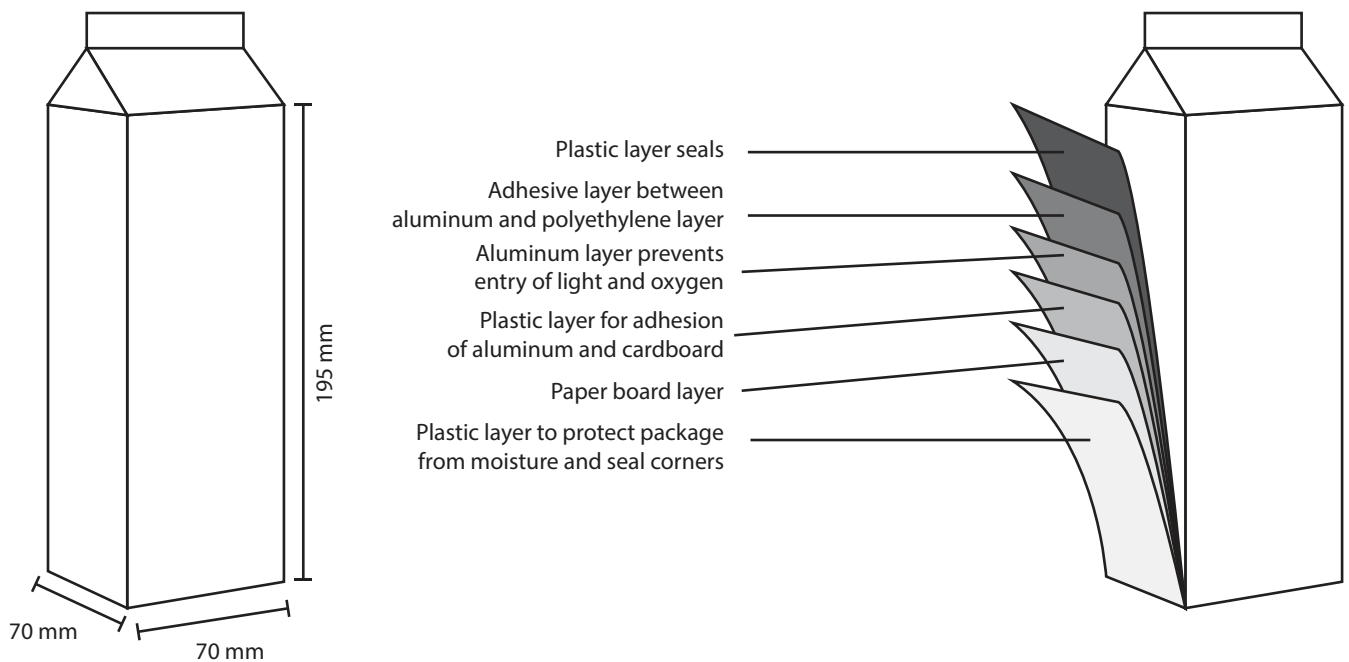

[Source: © International Baccalaureate Organization 2016]

- (a) (i) State **one** piece of anthropometric data important to the design of the carton in **Figure 1**.

[1]

.....

.....

(This question continues on the following page)



24EP02

**(Question 1 continued)**

(ii) Outline **one** reason for the design of the flap at the top of the Tetra Pak carton. [2]

.....

.....

.....

.....

.....

.....

(b) (i) Outline **one** advantage of the multiple layer construction of the Tetra Pak carton. [2]

.....

.....

.....

.....

.....

.....

(ii) Outline why the Tetra Pak company uses a trademark symbol (™) on its cartons. [2]

.....

.....

.....

.....

.....

.....

**(This question continues on the following page)**



24EP03

Turn over

**(Question 1 continued)**

- (c) (i) Outline **one** method that the Tetra Pak company could use to increase the recyclability of its cartons.

[2]

.....

.....

.....

.....

.....

.....

- (ii) Explain **one** advantage of the Tetra Pak cartons compared to the glass containers that they replaced.

[3]

.....

.....

.....

.....

.....

.....

.....

.....

.....

**(This question continues on page 6)**



24EP04

Please **do not** write on this page.

Answers written on this page  
will not be marked.



24EP05

Turn over

(Question 1 continued)

**Figure 2a** shows the quantity (billions) and **Figure 2b** the recycling rate (percent) of used Tetra Pak cartons since 2008. Tetra Pak management wishes to increase the recycling rate to 40% by 2020, double the rate in 2010.

**Figure 2a: The number, in billions, of used Tetra Pak cartons recycled over a six-year period**

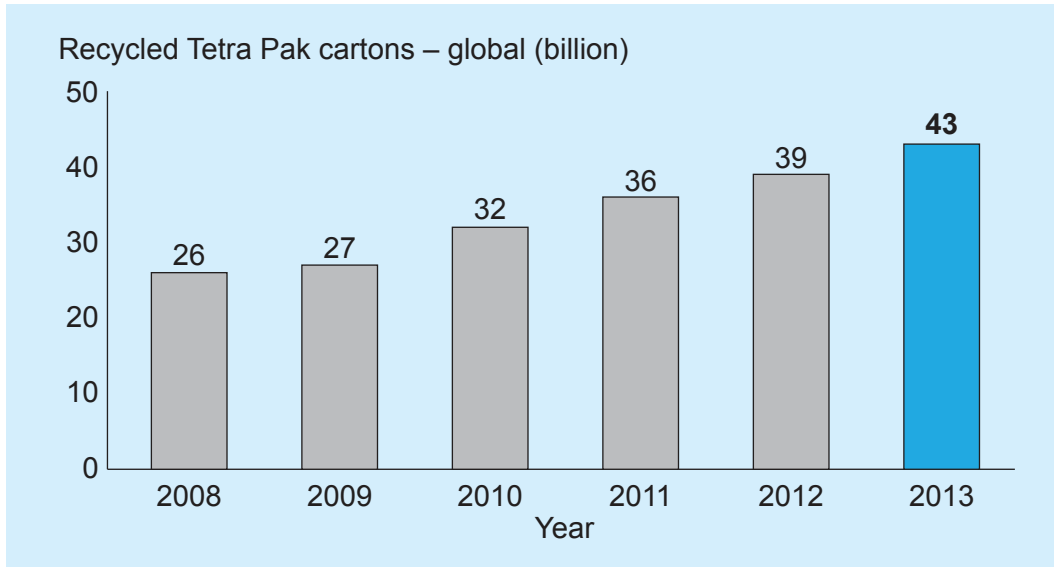

[Source: <http://sustainability.tetrapak.com>]

**Figure 2b: The percentage of cartons recycled over the same six-year period**

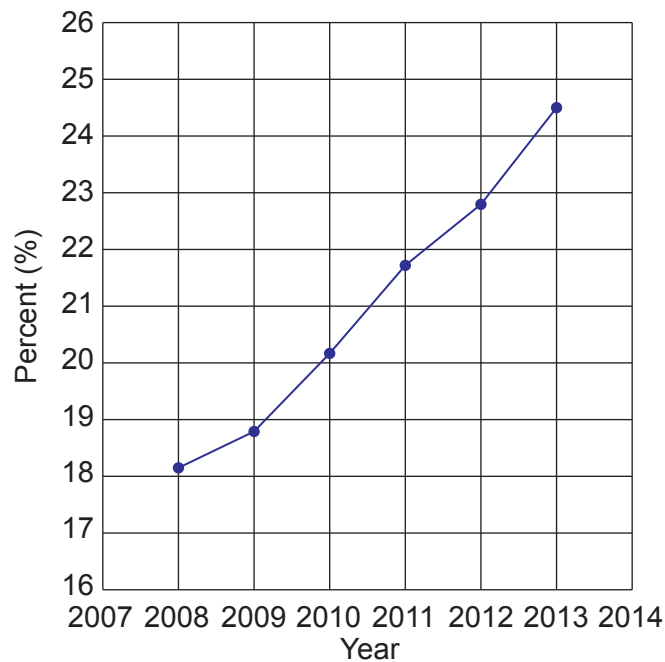

[Source: <http://sustainability.tetrapak.com>]

(This question continues on the following page)



24EP06

**(Question 1 continued)**

- (d) (i) Using the information provided in **Figures 2a** and **2b**, calculate how many Tetra Pak cartons would have been manufactured in 2013. You must show your workings. [2]

.....

.....

.....

.....

.....

.....

- (ii) Outline **one** disadvantage of the Tetra Pak cartons compared to the glass containers that they replaced. [2]

.....

.....

.....

.....

.....

.....

**(This question continues on the following page)**



**(Question 1 continued)**

- (e) (i) Outline **one** implication of dematerialization for the design of the Tetra Pak carton.

[2]

.....

.....

.....

.....

.....

.....

- (ii) Outline **one** effect on the environment of the production of cardboard cartons.

[2]

.....

.....

.....

.....

.....

.....



24EP08



Please **do not** write on this page.

Answers written on this page  
will not be marked.



24EP09

Turn over

2. Many bottles and cartons are sealed with screw caps as in **Figure 3**. Designers pay a great deal of attention to the force needed, torque, to turn the screw cap.

Torque is calculated as follows:  $T = F \times d$

Where:

$T$  – torque or turn necessary to open the screw cap, in Newton-metres (Nm)

$F$  – handgrip force necessary to create friction to create torque, in Newtons (N)

$d$  – diameter of the screw cap, in metres (m), see **Figure 4**.

Package designers assume that users with no physical disability can produce a torque of 6.3Nm.

**Figure 3: Opening a screw cap carton**

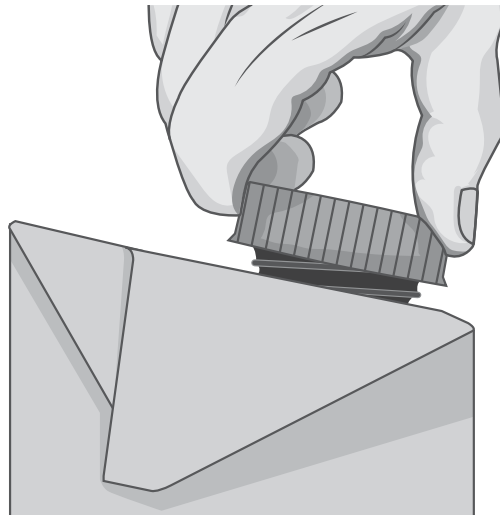

[Source: © International Baccalaureate Organization 2016]

**Figure 4: Dimensions of the screw cap and indication of the direction of force applied**

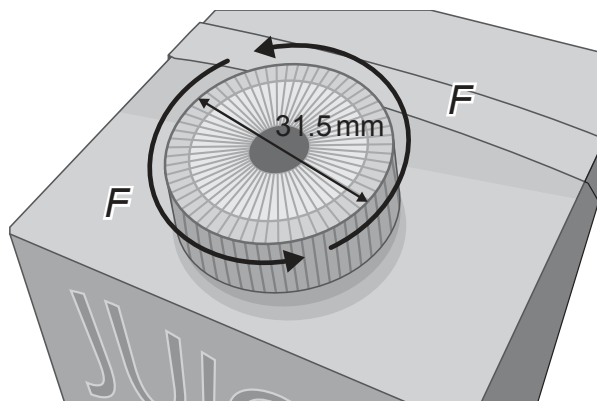

[Source: © International Baccalaureate Organization 2016]

(This question continues on the following page)



24EP10

**(Question 2 continued)**

- (a) Calculate the handgrip force applied as shown in **Figure 4**, to the screw cap if the required torque to open it is 6.3 Nm.

[2]

.....

.....

.....

.....

.....

.....

- (b) Outline **one** physiological factor related to the design of the screw cap.

[2]

.....

.....

.....

.....

.....

.....



24EP11

Turn over

3. Explain why a small company may not adopt life cycle analysis as a strategy for reducing the environmental impacts of its products.

[3]

.....

.....

.....

.....

.....

.....

.....

.....

.....

.....

.....

.....

.....

.....

.....

4. Discuss the implications of biodegradability in the development of new plastic materials.

[3]

.....

.....

.....

.....

.....

.....

.....

.....

.....

.....

.....

.....

.....

.....

.....



24EP12

Please **do not** write on this page.

Answers written on this page  
will not be marked.



24EP13

Turn over

### Section B

Answer **one** question. Write your answers in the boxes provided.

- 5. **Figure 5** shows the Woven Easy chair by Alexander Mueller. The chair has a hardwood frame (ash) which is stained to darken the wood. The seat and back of the chair are made from a single waxed cord. Cord is a textile material made from fibres.

**Figure 5: Woven Easy chair by Alexander Mueller**

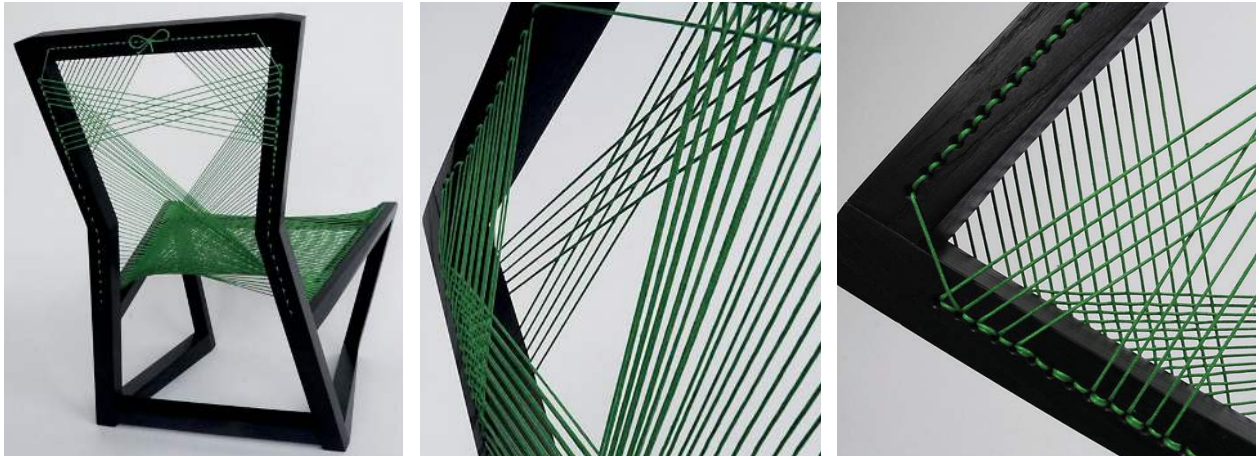

[Source: Alexander Mueller, [www.alexandermueller.co.uk/wove-easy-collection.html](http://www.alexandermueller.co.uk/wove-easy-collection.html)]

- (a) Outline **one** reason why the textile cord is treated with wax.

[2]

.....

.....

.....

.....

.....

.....

(This question continues on the following page)



24EP14

**(Question 5 continued)**

- (b) Explain why it is necessary for the textile fibres to be formed into a yarn to create the cord for the Woven Easy chair. [3]

.....

.....

.....

.....

.....

.....

.....

.....

.....

.....

- (c) Discuss the design of the Woven Easy chair in relation to the balance between form **and** function. [6]

.....

.....

.....

.....

.....

.....

.....

.....

.....

.....

.....

.....

.....

.....

.....

.....

.....

.....

.....

.....

.....

.....

.....

**(This question continues on the following page)**



24EP15





6. **Figure 6** shows the PlayShapes product by Miller Goodman. PlayShapes is a set of 74 modular hardwood shapes which are finished with paint or varnish. They can be used by young children of various ages to create hundreds of three-dimensional designs.

**Figure 6: PlayShapes product by Miller Goodman**



[Sources: <http://cdn2.ahalife.com>]

- (a) (i) State **one** advantage of using paint to finish the parts of the PlayShapes product. [1]

.....  
.....

- (ii) State **one** disadvantage of using paint to finish the parts of the PlayShapes product. [1]

.....  
.....

(This question continues on the following page)



24EP17

Turn over

**(Question 6 continued)**

- (b) Explain **one** characteristic of hardwood timber which is important for the nature of the PlayShapes design. [3]

.....

.....

.....

.....

.....

.....

.....

.....

.....

.....

- (c) Explain **two** advantages of combining computer-aided design (CAD) modelling with physical modelling to get feedback during the design development of the PlayShapes product. [6]

.....

.....

.....

.....

.....

.....

.....

.....

.....

.....

.....

.....

.....

.....

.....

.....

.....

.....

.....

.....

.....

.....

**(This question continues on the following page)**



24EP18



- 7. **Figure 7** shows the Babolat Play Pure Drive tennis racquet. The racquet handle contains sensors that collect data on the performance of the tennis player. This data is sent to a computer or smartphone that provides the user with feedback on their performance.

An example of this data is shown in **Figure 8**. In January 2014, after 10 years of development, the racquet was approved for use in competitions by the International Tennis Federation. The racquet has 2 buttons and a USB port inside the handle with a memory capacity of 150 hours of tennis-playing time and a battery life of six hours.

**Figure 7: The Babolat Play Drive tennis racquet**



[Sources: www.ubitennis.com and www.ifftennis.com]

**Figure 8: Data gathered from the Play Pure Drive tennis racquet**



[Sources: www.eskimag.fr]

(This question continues on the following page)



24EP20

**(Question 7 continued)**

- (a) Outline the influence of technology push on the design of the Play Pure Drive tennis racquet.

[2]

.....

.....

.....

.....

.....

.....

- (b) Explain why the product life of the Play Pure Drive tennis racquet is likely to be shorter than the product life of a conventional tennis racquet.

[3]

.....

.....

.....

.....

.....

.....

.....

.....

.....

**(This question continues on the following page)**



24EP21

**Turn over**





Please **do not** write on this page.

Answers written on this page  
will not be marked.



24EP24